

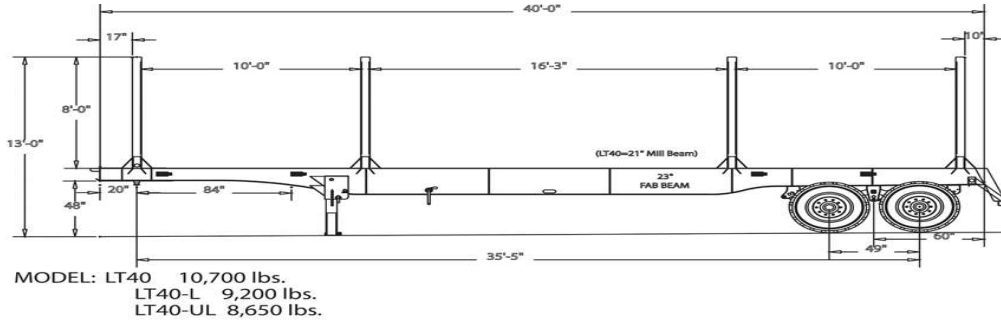

PH. 800-321-8073

FX. 334-855-3507



**Model LT40-L**

[www.pittrailers.com](http://www.pittrailers.com)

STANDARD FEATURES	LOAD PAYIN SERIES
Load Capacity _____	80,000 lbs.
Weight _____	9,450 lbs.
Overall Length _____	40'
Width _____	8'6"
King Pin Swing Radius _____	84"
King Pin Setting _____	20"
King Pin Area _____	Covered with Two Hinged Tool Boxes
Fifth Wheel Height _____	48"
Mainframe _____	21" Fabricated - T1 Steel - Straight Frame
Cross Members _____	Channel Iron w/ "X" Members
Bumper _____	Extended Push Bumper, 4"x 6"x 102"
Bolsters _____	4"x 10"x 102", High Yield Steel
Standards _____	5"x 5", High Yield Steel, 13' Overall
Landing Gear _____	Heavy Duty Winch Back, 7" Foot
Air Tank _____	Covered
Winches _____	With Four 30' Straps
Suspension _____	Hutch 3 Point, Four Spring w/ 14,000lbs Cap. Springs
Axles _____	25,000 lbs. cap. 77.5" Track, Auto Slack Adjusters, Type 30 Brake Chambers, 16 1/2"x 7" Brake Pads
Tires _____	11R24.5 Radials
Wheels _____	10 Hole Disc, Hub Piloted
Wiring _____	D.O.T. Sealed Wiring Harness, Sealed Lights Rubber Mounted
Paint _____	Black (Two Part Primer w/ Two Part Polyurethane Paint)

\*\*\*NOTE\*\*\* ALL SPECIFICATIONS SUBJECT TO CHANGE WITHOUT NOTICE. WEIGHTS AND DIMENSIONS ARE APPROXIMATE

**OPTIONAL EQUIPMENT**

BOGIE	
Type 30/30 Spring Brakes _____	add 40 lbs.
Single Point (2 Spring) entire length of tandem covered with channel iron _____	add 800 lbs.
Air Ride entire length of tandem covered with channel iron _____	add 310 lbs.
Air Lift One Axle _____	add 135 lbs.
Lift Kit - Air Lift One Axle on a Single Point Suspension _____	add 95 lbs.
Add a Third Axle (Spring Ride) _____	add 1,800 lbs.
Add a Third Axle (Air Ride) _____	add 1,885 lbs.
11R.22.5 Tires _____	deduct 88 lbs.
425/60R22.5 Super Singles on Aluminum Disc Wheels _____	deduct 595 lbs.
Aluminum Wheels (Outside Polished) _____	deduct 280 lbs.
Tire Inflation System _____	
Onboard Electronic Scales (trailer only) (Vulcan or SI) _____	add 55 lbs.
Truck Only (not installed) _____	
Auto I.D. transmitter for multiple trucks, trailers _____	
Onboard Air Scales (trailer only) _____	add 30 lbs.
Air Gauge In Sealed Box _____	

**MISCELLANEOUS**

- Revolver Greaseless Coupling System (Eliminates Need To Grease 5<sup>th</sup> Wheel) \_\_\_\_\_ add 40 lbs.
- Headboard add 450 lbs.
- Additional Length add 60 lbs. per ft.
- Steel Fenders (Front Mud Guard)
  - (Full Front Fender)
  - (Rear Tandem Fender)
- Drag Bar Behind Back Bolster
- Additional Winches (cables or strap)
- 1/2" Kingpin Plate add 60 lbs.
- Two-Speed Landing Gear deduct 165 lbs.
- Grapple Deflectors
- Standard Vertical Flat Bar Type - Center Section Only add 40 lbs.
- "V" Type - Deflects Grapple - Center Section Only add 85 lbs.
- Grapple Bar off Rear Bumper add 85 lbs.
- 8' Wide Trailer deduct 100 lbs.
- Moveable Bolsters add 50 lbs each
- Additional Bolsters add 450 lbs.
- Removable Standards
- Additional Lights
- Special Paint Color (Any Color Other Than Black)